

SBE 37-IMP MicroCAT CT(D)

The SBE 37-IMP pumped MicroCAT is a high-accuracy conductivity and temperature (pressure optional) recorder with integrated Inductive Modem (IM) interface, internal batteries, memory, and integral Pump. The MicroCAT is designed for long-duration deployments on moorings.

Data is recorded in memory and can be transmitted when polled through inductive modem telemetry. Measured data are output in engineering units.

Memory capacity exceeds 530,000 samples. Battery endurance varies, depending on sampling scheme. Sampling every 3 minutes, the MicroCAT can be deployed for 2 years (380,000 samples).

Features

- Moored Conductivity, Temperature, and Pressure (optional), at user-programmable 6-sec to 6-hour intervals.
- Integral pump.
- Inductive Modem (IM) interface.
- Internal memory and battery pack.
- Expendable anti-foulant devices, unique flow path, and pumping regimen for bio-fouling protection.
- 350 m plastic or 7000 m titanium housing.
- Seasoft® V2 Windows software package (setup, data upload, and data processing).
- Field-proven MicroCAT family, with more than 10,000 instruments deployed.
- Five-year limited warranty.

Components

- Inductive Modem (IM) system provides reliable, low-cost, real-time data transmission for up to 100 IM-enabled instruments using plastic-coated wire rope (typically 3x19 galvanized steel) as both transmission line and mooring tension member. IM instruments clamp anywhere along the mooring, which is easily reconfigured by sliding and re-clamping instruments on the cable. In a typical mooring, an Inductive Modem Module (IMM) in the buoy communicates with IM instruments and interfaces to a computer/data logger (not supplied by Sea-Bird) via RS-232. The data logger is programmed to poll each IM instrument for data, and sends the data to a satellite link, cell phone, etc.
- Unique internal-field conductivity cell permits use of expendable anti-foulant devices, for long-term bio-fouling protection.
- Aged and pressure-protected thermistor has a long history of exceptional accuracy and stability.
- Optional strain-gauge pressure sensor with temperature compensation is available in eight ranges (maximum depth 7000 m).
- Pump runs for 1 second for each sample, providing improved conductivity response and bio-fouling protection.



Deploy in
orientation shown
(sensors at top)
for proper operation

Options

- Plastic (350 m) or titanium (7000 m) housing.
- No pressure, or strain-gauge pressure sensor in one of 8 ranges.
- Wire guide and mounting clamp in one of 10 sizes.

Measurement Range

Conductivity	0 to 7 S/m (0 to 70 mS/cm)
Temperature	-5 to 45 °C
Optional Pressure	20 / 100 / 350 / 600 / 1000 / 2000 / 3500 / 7000 (meters of deployment depth capability)

Initial Accuracy

Conductivity	± 0.0003 S/m (0.003 mS/cm)
Temperature	± 0.002 °C (-5 to to 35 °C); ± 0.01 °C (35 °C to 45 °C)
Optional Pressure	± 0.1% of full scale range

Typical Stability

Conductivity	0.0003 S/m (0.003 mS/cm) per month
Temperature	0.0002 °C per month
Optional Pressure	0.05% of full scale range per year

Resolution

Conductivity	0.00001 S/m (0.0001 mS/cm)
Temperature	0.0001 °C
Optional Pressure	0.002% of full scale range

Acquisition Time	1.9 - 2.6 sec/sample (see manual)
Power Supply & Consumption	7.8 Amp-hour (nominal) battery pack (derated for calculations); 380,000 samples CTD (see manual)
Memory Capacity	530,000 samples CTD
Housing, Depth Rating, & Weight	Plastic: 350 m, 3.6 kg in air, 1.7 kg in water Titanium: 7000 m

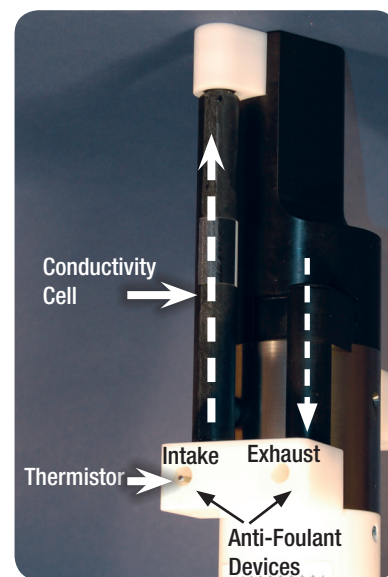
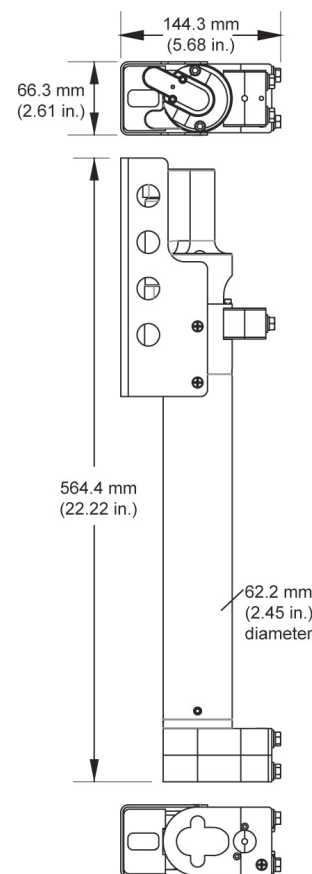

Pumped flow through conductivity cell (conductivity cell guard removed)